

KV 250 L SILEO

Артикул 19519

Версия: 50 Hz

Тип документа: **Технический паспорт**
 Дата создания: **2016-01-29**
 Создано с помощью: **Systemair Онлайн Каталог**



Описание

- Speed-controllable
- Quiet-running
- Increased efficiency
- Integral thermal contacts
- Can be installed in any position - duct or wall mounted
- Can be installed outdoors
- Maintenance-free and reliable

The KV sileo series is designed for installation in ducts. All KV-fans have minimum 25 mm long spigot connections. The FK mounting clamp facilitates easy installation and removal, and prevents the transfer of vibration to the duct. The fans have backward-curved blades and external rotor motors. KV sileo fans can be speed-controlled via a stepless thyristor or a 5-step transformer. To protect the motor from overheating the fan has integral thermal contacts with manual reset.

The casing is manufactured from galvanised sheet steel and folded which gives the fan a close to air tight casing, wet room applications of the fan are possible due to the air tight casing.

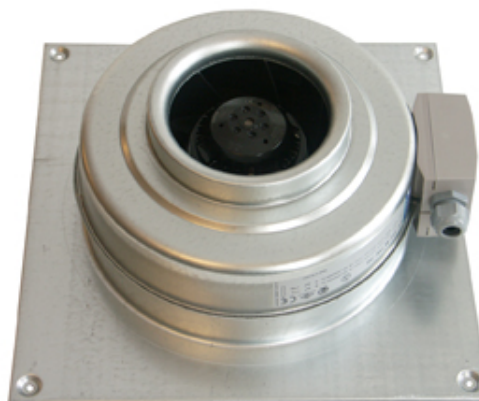

Технические данные

Номинальные параметры		
Напряжение	230	В
Частота	50	Гц
Фазность	1	~
Входная мощность (P1)	148	Вт
Ток	0,648	А
Макс. расход воздуха	983	м³/ч
Частота вращения	2556	1/мин
Максимальная температура перемещаемого воздуха	70	°С
Максимальная температура перемещаемого воздуха при регулировании	70	°С
Уровень звукового давления на расстоянии 3м (20м² Сэбин)	46,9	дБ(А)
Вес	4,6	кг
Класс изоляции	F	
Класс защиты двигателя	44	IP
Емкость конденсатора	3,5	мкФ
ErP		
ErP ready	2016, 2018	

Характеристики

Диаграммы

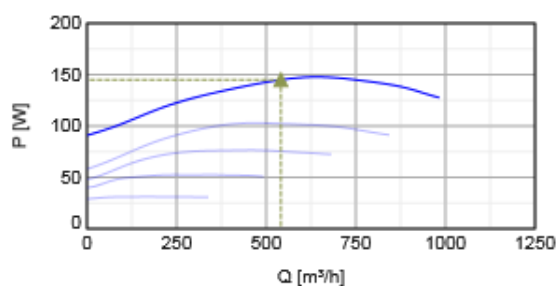
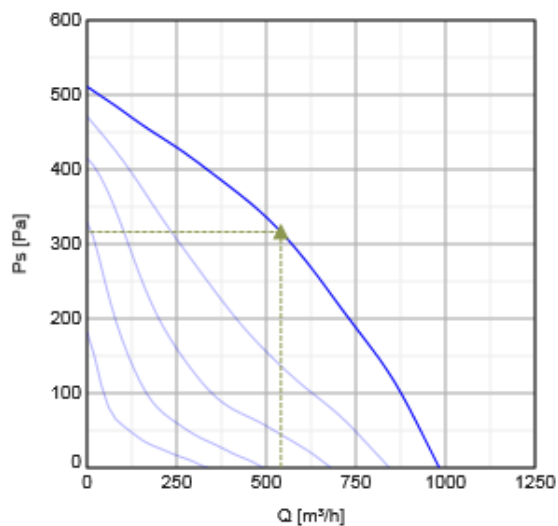

Гидравлические данные

	Рабочая точка						
	Q [м³/ч]	Ps [Па]	P [Вт]	n [1/мин]	I [А]	SFP [кВт/м³/с]	U [В]
Макс. эффективнос	▲ 541	▲ 316	▲ 145	2564	0.635	0.966	230

Акустические данные

Уровень звук. мощности	63	125	250	500	1k	2k	4k	8k	Общ.
Вход									
Выход									
К окружению									

Размеры



Схема подключения



Принадлежности

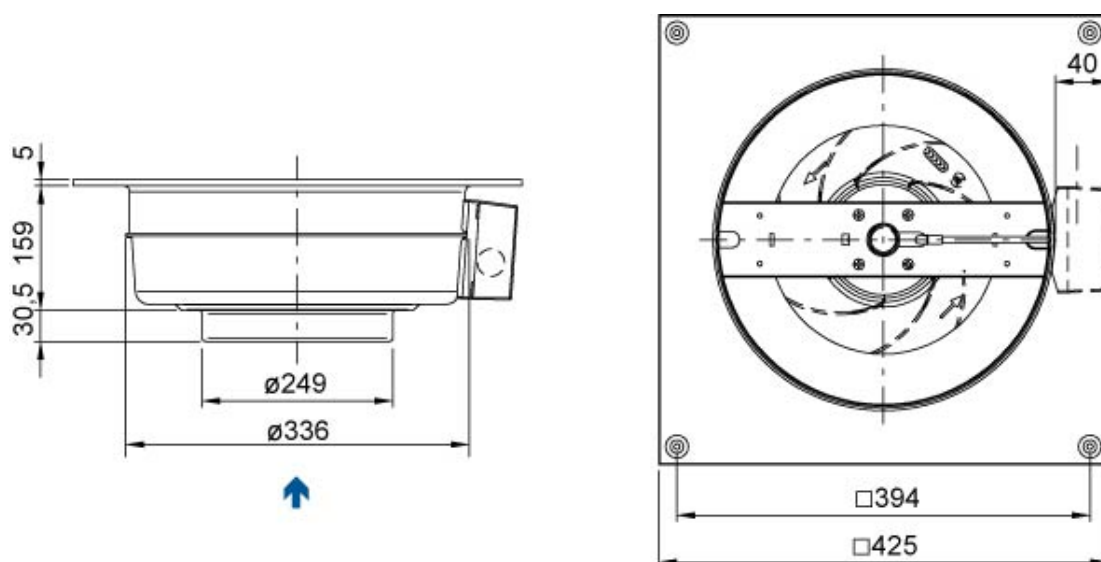
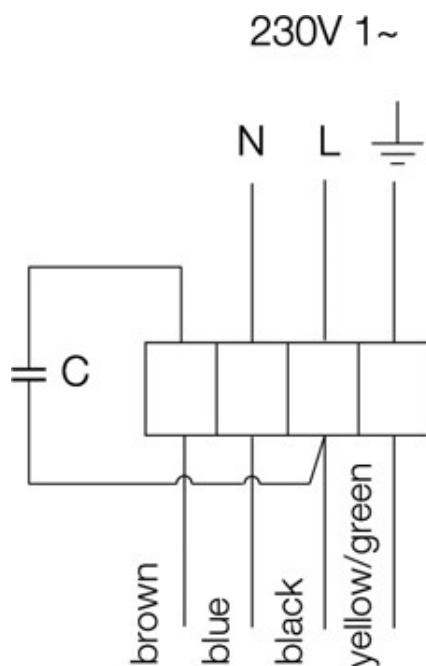

Электрические принадлежности

- CO2RT-R-D Transmitter (6993)
- Presence detector/IR24-P (6995)
- REV-3POL/03 ON/OFF (33978)
- REE 1 Speed control (5314)
- RT 0-30 Room Thermostat (5151)
- DTV500-OEM incl connection kit (5044)
- HR1 Room Humidistat IP21 (5150)
- T 120 Timer (5165)
- REPT 6 Digital regulator (5698)
- REU 1.5 Speed control (5004)
- RE 1,5 Speed control (5000)

Принадлежности

- CBM 250-6,0 400V/2 Duct heater (9089)
- VBC 250-2 Water heating batt (5460)
- VBC 250-3 Water heating batt (9843)
- RSK-250 Back draft damper (5603)
- SG 250 Protection guard (5610)
- VK-35 Louvre shutter (5642)
- LDC 250-900 Silencer (5196)
- CWK 250-3-2,5 Duct cooler,circ (30024)
- FFR 250 Filter cassette (1776)
- FK 250 Fast clamp (1612)
- VKK-250 Back draft damper (1627)
- FGR 250 Filter cassette G3 (1815)

Документация

-  Certificates_GOST_2010.pdf (2,00MB)
-  Certificates_UkrSepro_2010-2011.pdf (705,31kB)
-  202341_Fans_Instructions_CE_A004.pdf (1,68MB)

Eco design

Trade name	Systemair
Product name	KV 250 L Sileo
ErP compliance	2018
Unit category	NRVU
Drive	External MSD or VSD

Unit type	UVU
Heat recovery type	None
Temperature ratio (UVU)	Not applicable
qv nom	541 м³/ч
P nom	145 Вт
Ps nom	316 Па
Fan efficiency	33 %
External Leakage	5 %
Звуковая мощность	48 дБ(А)

Specification text

KV 250L TW Circular duct fan
DN250, 230V50Hz, 1~, imp. backw. curved

Circular duct fan for wall mounting, easy and direct installation in ducts.
Galvanized sheet steel housing.
Circular connection spigot, length 25mm, acc. to EN1506:1997

Free-running, backward curved centrifugal impeller made of plastic.
Balancing made to G 6.3, motor compl. with impeller statically and dynamically balanced in two planes acc. to DIN ISO 1940 T.1.

Voltage controllable external rotor motor, maintenance-free, the motor is placed inside the air flow for cooling. Integral thermal contacts with manual reset acc. to EN 60335-2-80, speed-controlled via a 5-step transformer or a stepless thyristor. Silent, long-life ball bearings. Terminal box (IP55) on the casing.

Mounting brackets included in delivery.

For indoor, outdoor installation as well as in wet areas.
Air leakage class C acc. to EN 12237:2003.
Installation in any mounting position.

PRODUCT: SYSTEMAIR
TYPE: KV 250L TW
Item no. 1218